



Building and Planning Division
Transportation, Infrastructure and Energy

PO Box 2000
Charlottetown
Prince Edward Island
Canada C1A 7N8

Tel 902 368 5060
Fax1 902 368 5395
Fax2 902 569 0590
www.gov.pe.ca/

Addendum

**Kensington Post Office
Interior Modifications
2478-17064**

ADDENDUM # 1

Date : January 10, 2018

Page 1 of 1

The following amendment to the tender documents is effective immediately. This addendum shall form part of the contract documents.

Note: Please indicate this addendum number on the Contract Tender Form.

<u>Item</u>	<u>Description</u>
A-1-1	<p><u>Refer to Specification Section A2 - Scope of Work</u></p> <p>Add the following;</p> <p>12. Contractor to patch and repair wall cracking inside Post Office Main Entrance Vestibule (approx 1.4 sq.m. (15 sq.ft.)). Prime and paint entire vestibule. Colour to match existing.</p> <p>13. Contractor to remove wooden bulkhead at windows in the Customer Service Area. Replace with ACT return as per attached SK-1.</p> <p>14. Contractor to supply and install Fire Rated 24"x24" access hatches as per the attached drawing A1-R. Paint to match existing ceiling finish.</p>
A-1-2	<p><u>Refer to Specification Section B - Instruction to Bidders, 4.Construction Schedule</u></p> <p>Remove item 4.d from the specification.</p>
A-1-3	<p><u>Refer to A1 - Main Floor Plan</u></p> <p>Replace existing drawing A1 with the attached revised drawing A1-R.</p>

- END OF ADDENDUM -

← TO SUMMERSIDE (RT. #2)

POST OFFICE ENTRANCE

GARDEN DRIVE

TO CHARLOTTETOWN (RT. #2) →

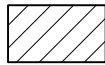
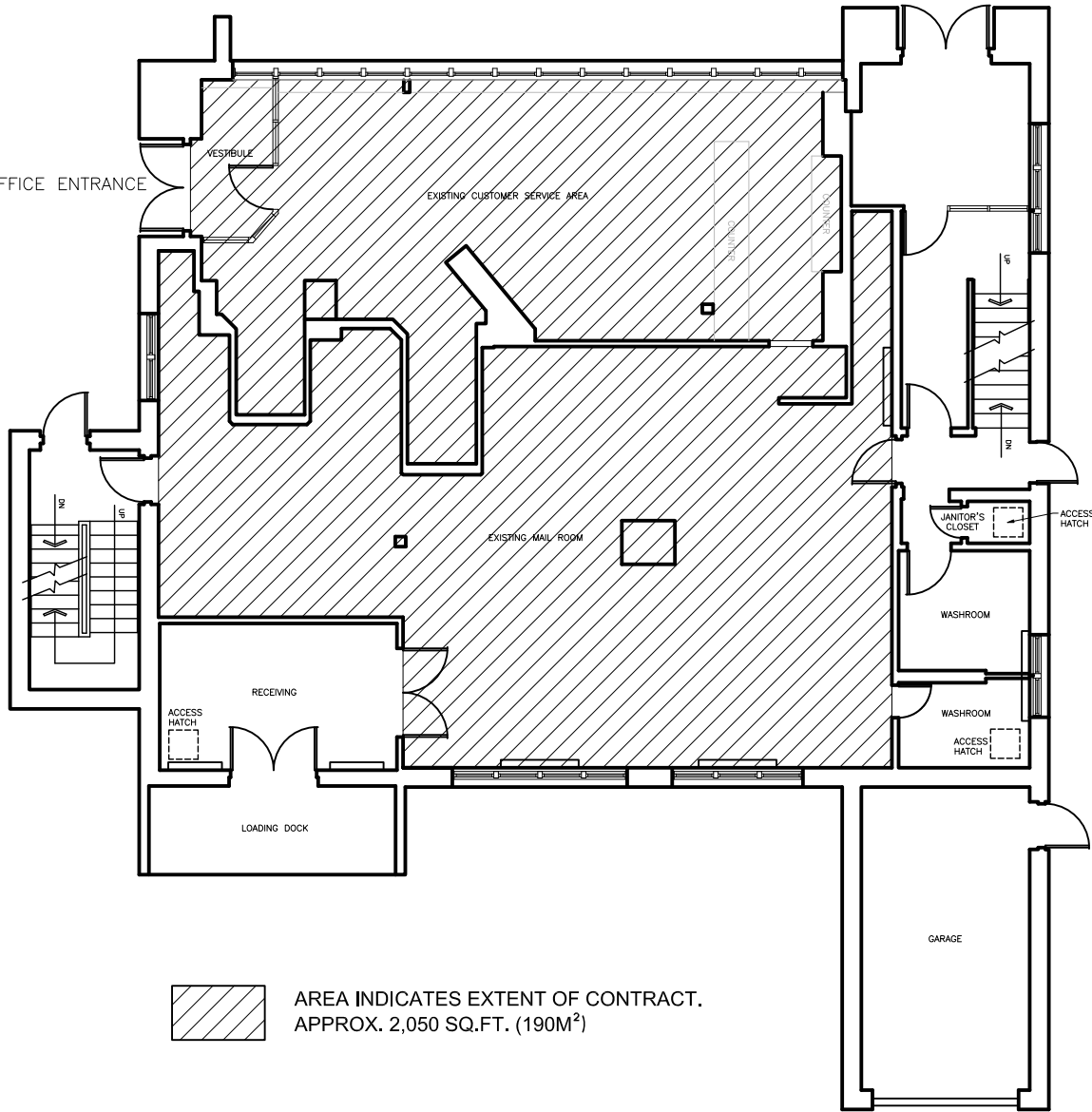

AREA INDICATES EXTENT OF CONTRACT.
APPROX. 2,050 SQ.FT. (190M²)

GENERAL NOTES:

1. ALL MEASUREMENTS AND SITE CONDITIONS ARE TO BE CONFIRMED ON SITE BY THE CONTRACTOR. CONTRACTOR IS RESPONSIBLE TO VISIT THE SITE PRIOR TO SUBMITTING A TENDER AND MAKE THEMSELVES FAMILIAR WITH CONDITIONS THAT MAY AFFECT THE WORK.
2. REMOVAL AND DISPOSAL OF DEMOLISHED MATERIALS TO BE IN ACCORDANCE WITH AUTHORITIES HAVING JURISDICTION.
3. CONTRACTOR RESPONSIBLE TO MAKE GOOD ALL AREAS AFFECTED UNDER THIS CONTRACT BACK TO ITS ORIGINAL CONDITION. (MATCH EXISTING)

Project Title: *Kensington Post Office
Interior Modifications*

Drawing Title: *Main Floor Plan*



Date:
01-10-18

Dsgn By:
TIE

Drn By:
J.Gauthier

Scale:
1:150

Proj No.:
2478 - 17064

Dwg No.:
A1-R

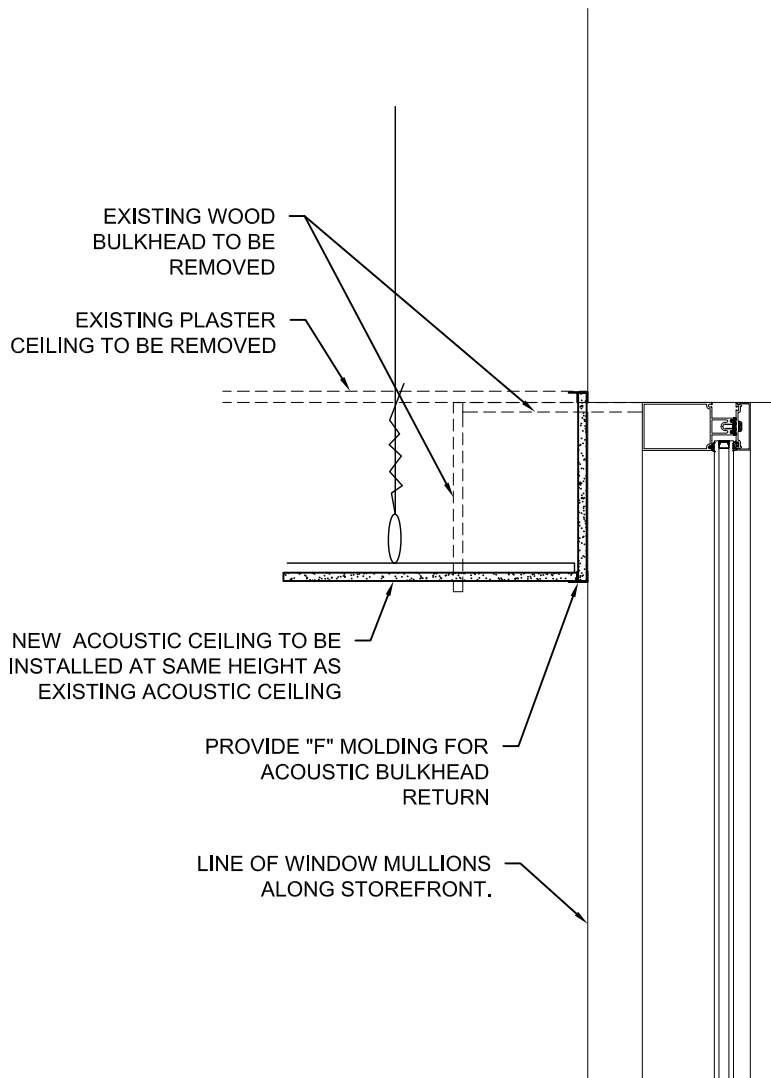

CEILING DETAIL @ WINDOWS IN CUSTOMER SERVICE AREA

1:10

G:\BLDG ASSET\BLDG\2478 KENSINGTON POST OFFICE\17064 CEILING TILES\DWG\2478-17064-R1.DWG

Project Title: *Kensington Post Office Interior Modifications*

Drawing Title: *Acoustic Ceiling @ Window Detail*



Date:
01-10-18

Dsgn By:
TIE

Drn By:
J.Gauthier

Scale:
1:10

Proj No.:
2478 - 17064

Dwg No.:
SK-1